



Microwave Transceiver Capability

NALARIS
LINWAVE

Linwave Technology – about us

Linwave Technology is a supplier of novel custom RF & Microwave products for a wide range of applications; based in Lincoln in the UK . Each of our solutions is tailored to meet a specific customer challenge and enhance their overall system performance.

Product Examples include Analogue and Digital Transceivers, Power Amplifiers, Sources, Multi-chip Hybrids and Millimetre wave Diode assemblies. Our products have already supported customers in the Defence, Avionics, Marine, Industrial, Satcom, Healthcare, Space, Wireless, Transport and Security market sectors.

We have a unique combination of broad market alignment and deep technology understanding that can help solve some of today's most complex RF problems. Linwave solutions can range from open die IC's -utilising on site wire bonding and clean room facilities, up to modules with integrated software GUI. Products can be subjected to environmental approval plans in association with appropriate market & legislative directives proving compliance ahead of further systems integration. Our engineered integrated solutions provide top tier customers with options to add functionality for enhanced systems performance for key SWaP (size weight power) advantages.

Unique bespoke solutions need close working relationships. We excel at close collaboration to ensure project scope is understood and can be delivered effectively.



Linwave Technology – about us

- Product is structured around four key product pillars to exploit key skills and technologies within the Business:-

[Converters and Transceivers](#) / Amplifiers & Sources / Hybrid Multichip QFN Modules / Semiconductors

- We offer a broad range of design and manufacturing capability which is unique amongst UK SMEs, including:-
 - RF design and performance enhancement capability.
 - Specialist vertical design integration from die up.
 - Chip and wire design and build capability.
 - Design & test capability to 94GHz.
 - ITAR-free designs where needed.
 - AS9100 Qualified – solutions flying for commercial and Defence Avionics.

Facilities & Capabilities – Clean Room

- Class 10000 clean room.
- Temperature and humidity controlled.
- Inert gas hermetic sealing – vacuum furnace and projection welding facilities.
- Wafer probe capability.
- Manual and Semi-Automated ball, wedge tape and wire bonding.



Facilities & Capabilities - Assembly

- Hybrid chip & wire assembly capability:-
 - Epoxy die attach.
 - Gold wedge, ball, ribbon bonders.
 - Bond pull tester.
 - Eutectic die attach.
 - Wet etch capability.
 - Dry Nitrogen backfill.
 - Gap welder.
 - Vacuum furnace.
 - Custom specific tooling.



Facilities & Capabilities - Test

- Spectrum, Vector, Power, Noise and Scalar Analysis to 110 GHz.
- Modulated test sources & AW capability.
- Phase noise capability.
- Temp cycle facilities.
- Measurement automation routines for repetitive tests.
- Environmental testing including hot / cold store, Burn-in ovens and operational vibration and shock tests.

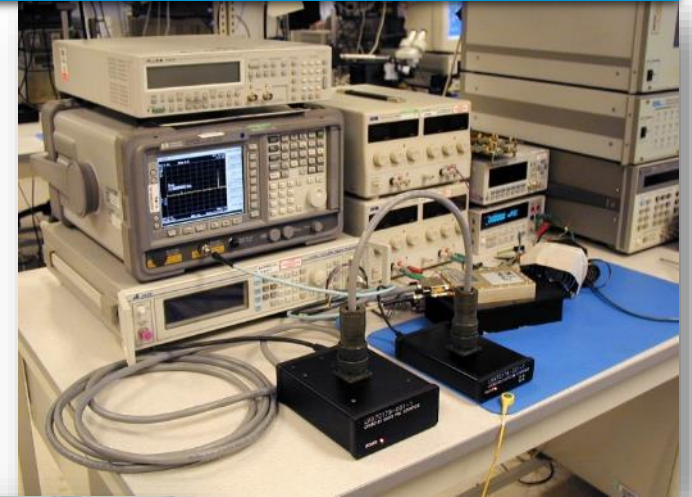

Defence Case Study – Radar TX/RX



Application: Airborne RADAR

Product Features :

- Transceiver containing 2 channel down converters
- Analogue to digital conversion capability
- Internally generated high accuracy system clock levels
- Built in test circuitry for fault detection and isolation
- Selectable TX filtering
- Programmable gain
- Digital interface
- Wide operational temp range -40 / +85C



Avionics Case Study – Ka Band TRM



Application: Airborne Data link UAV

Product Features:

- Steerable phased array Ka band system
- Separate Tx and Rx active elements
- Small physical size
- Designed to minimise effects of phase noise
- Design re-use and standardisation for Tx and Rx channels
- L Band input – up & down converters

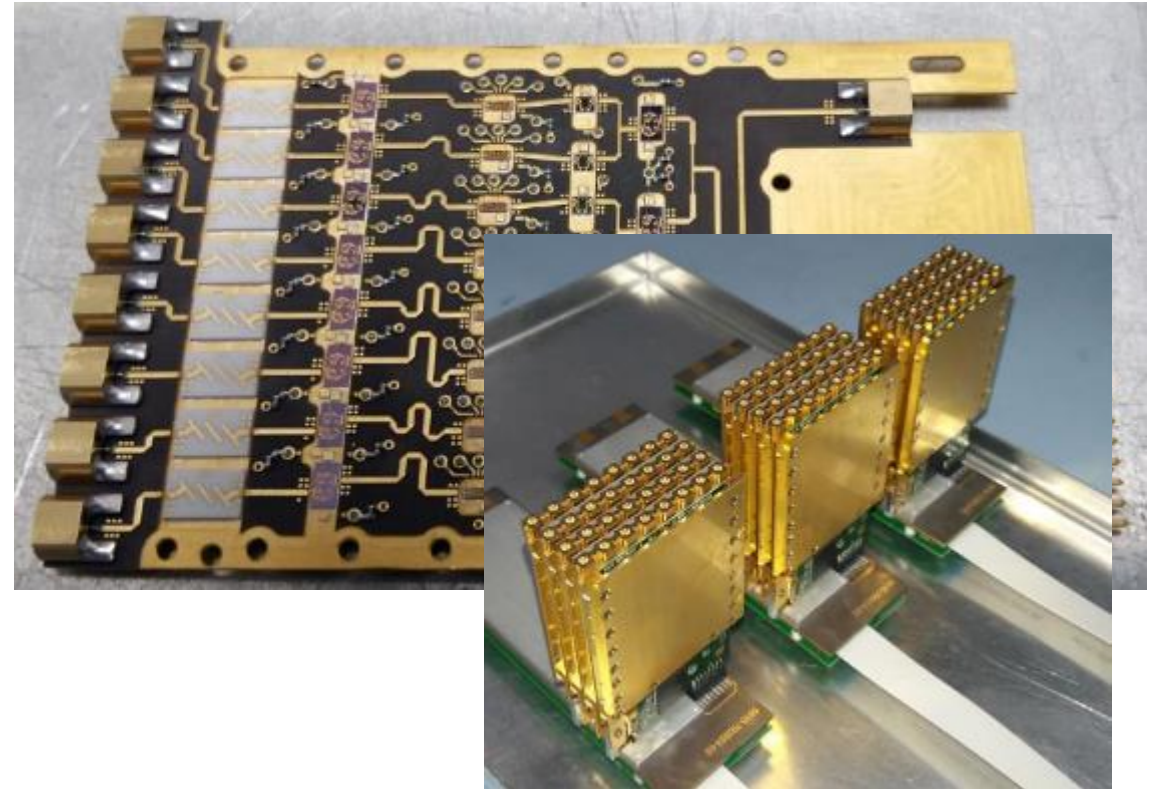

Case Study – Ku Band Converter



Application: Airborne Data link Ku

Product Features:

- L band to Ku @ 16W linear o/p
- Fan-less Operation
- Custom enclosure for exposure to high altitude 55,000ft
- Integrated Power Amp and Converter for SWaP improvements
- IESS 308 compliant

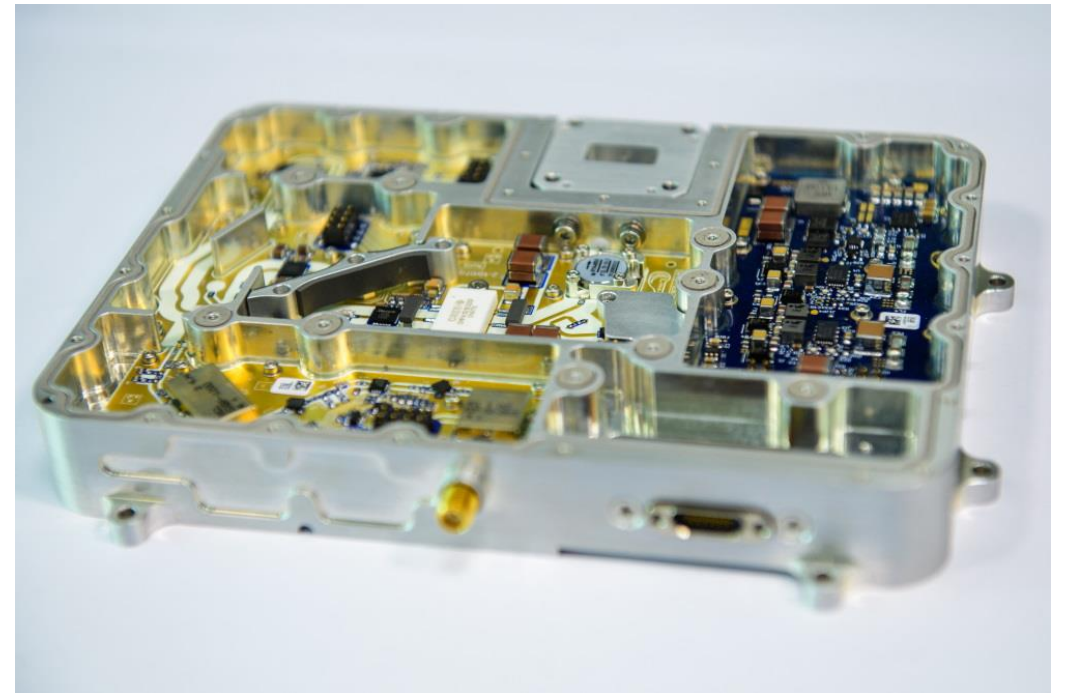

Case Study – Ka Band Converter

Application: Airborne Data link Ka

Product Features:

- L band to Ka @ 10-16W o/p
- Fan-less Operation
- Custom enclosure for exposure to high altitude 55,000ft
- Integrated Power Amp and Converter for SWaP improvements
- Integrated power monitoring
- IESS 308 compliant

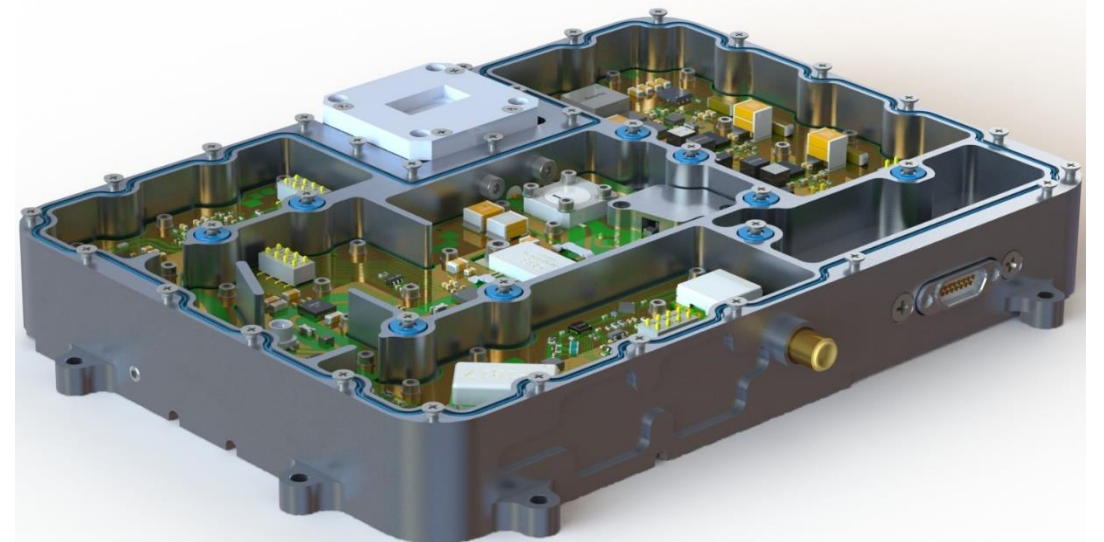
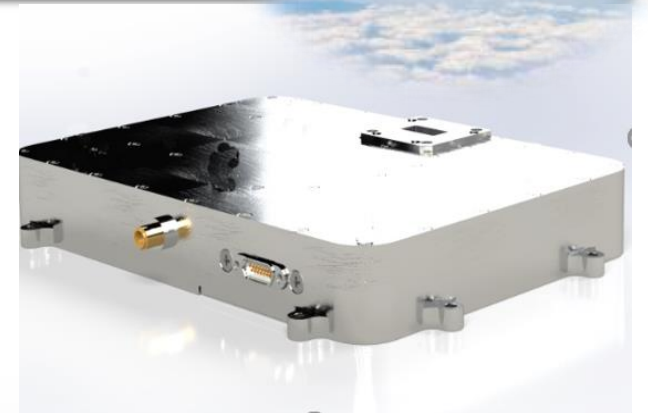

Avionics Case Study – Phased array



Application: Airborne Data link

Product Features:

- Hybrid technology adapted to integration of functions
- TRMs for beam forming using technology developed for Radar and now 5G
- Further devt of digital integration enhance performance

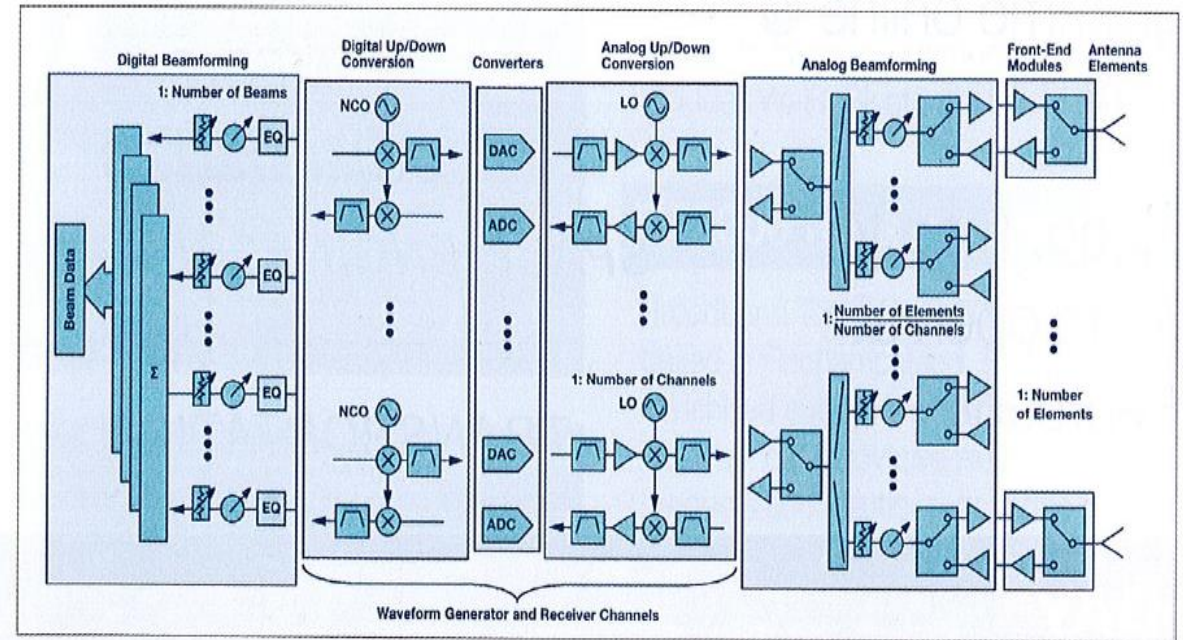

Figure 2. Generic beamforming phased array signal flow

Case Study – Ka Band Transceiver



Application: Airborne Data link Ka

Product Features:

- Tx Ka @ 10-16W o/p 29-30GHz
- Rx 19.2-20.2GHz Latest LNA technology for low noise
- Fan-less Operation, WG o/p & sma input
- Custom enclosure for exposure to high altitude 55,000ft
- Integrated Power Amp and Converter for SWaP improvements
- Integrated power monitoring
- DO-160G

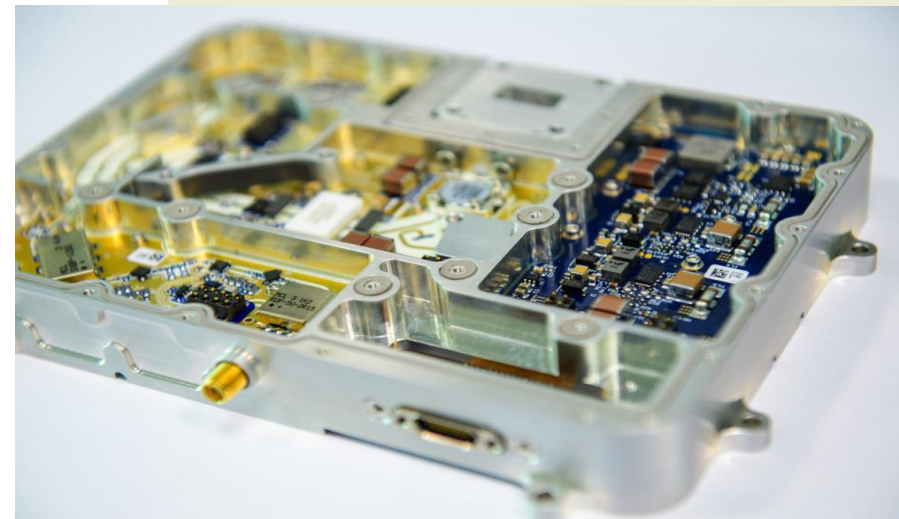
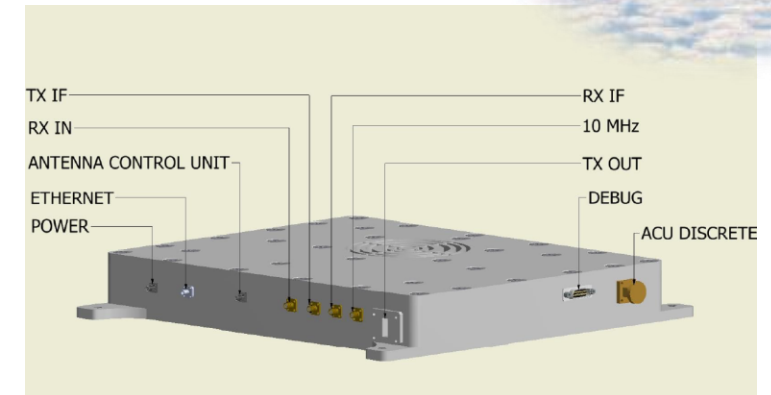

Capability Case Study – Converter Satcom Datalinks



- 25W Power BUC (combined amplifier and up-converter)
- X and DBS, Ku band options
- -60dBc spurious
- Small space envelope
- Comprehensive monitor & control and user definable options



Products & Technologies Summary

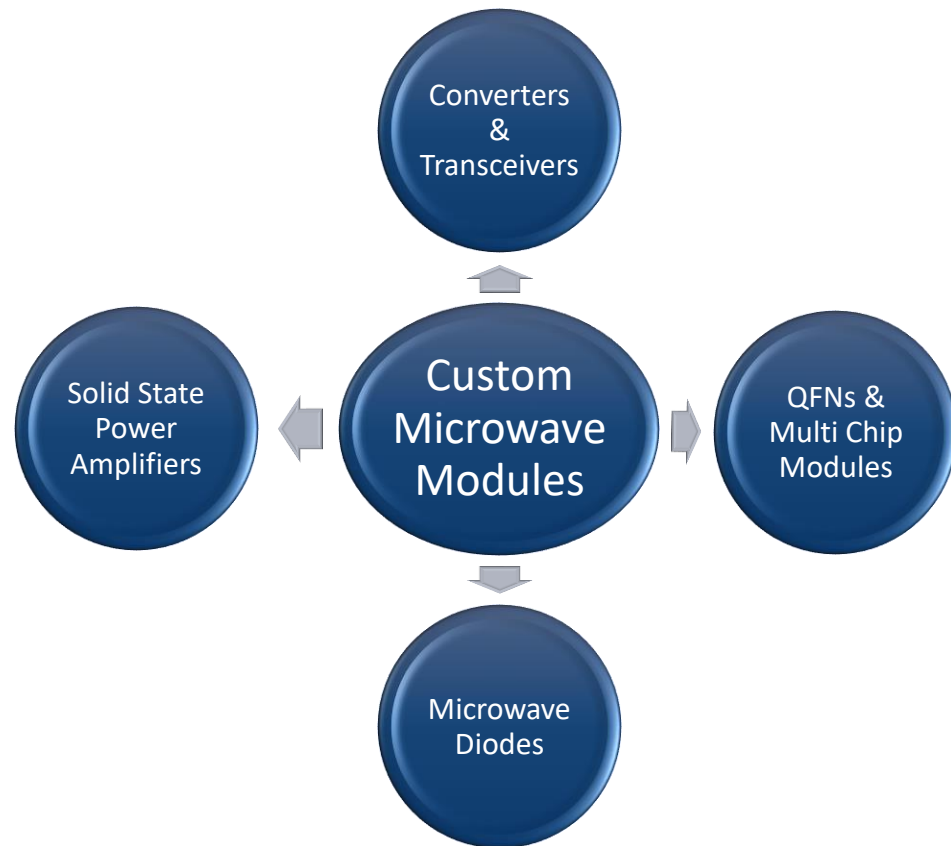

Linwave Technology
Marlin Building, 4 Sadler Rd
Lincoln LN6 3RS. UK.
Tel: +44 (0) 1522 681811
Email: sales@linwave.alaris.tech
Company Reg 04478971

