



ALARIS
KUHNE

INSPIRING THE NEXT RF SOLUTION

+49 (0) 9293 - 800 640
sales@kuhne.alaris.tech
www.kuhne.alaris.tech
Scheibenacker 3, 95180 Berg,
Germany

Version 1.0

KU LNC 1719 C PRO



Manual

Directors: Ian Duke/Gustav Wenhold
Reg no: HRB 3350 Hof, VAT-ID-No: DE 813343044, WEEEReg.-Nr. DE34186665

Kuhne electronic GmbH
Scheibenacker 3, 95180 Berg
Germany

A DIVISION OF

ALARIS
THE RF TECHNOLOGY GROUP



Specifications (Ta = 25 °C):

Type	KU LNC 1719 C PRO
Frequency range (RF)	1700 ... 1900 MHz
Noise figure @ 18 °C	typ. 0.4 dB, max. 0.6 dB
Gain (switchable)	typ. 48 dB (high gain), typ. 35 dB (low gain)
Output IP3	typ. +20 dBm (high gain), typ. +12 dBm (low gain)
IP1dB	typ. 11 dBm (high gain), typ. 2 dBm (low gain)
Switchable LO, IF frequencies	
Output frequency (LO 1400, 2200 MHz)	300 ... 500 MHz
Output frequency (LO 1500, 2100 MHz)	200 ... 400 MHz
LO accuracy @ 18 °C	+/- 1 kHz
LO frequency stability (0 ... 40 °C)	+/- 1 ppm
Phase noise @ 2040 MHz	
@ 1 kHz	typ. -100 dBc/Hz
@ 10 kHz	typ. -110 dBc/Hz
@ 100 kHz	typ. -103 dBc/Hz
Operating parameters	
Supply voltage	+9 ... 36 V DC
Current consumption	typ. 250 mA @ 12V (IF amplifier enabled)
Power consumption	typ. 3.0 W
Mechanics	
Input connector / impedance	SMA-female, 50 ohms
Output connector / impedance	SMA-female, 50 ohms
Case	milled aluminium, IP43
Dimensions (mm)	82 x 64 x 22
Weight	typ. 230 g
Absolute ratings	
Maximum RF input power	1 mW (0 dBm)
Operating case temperature range	-20 ... +55 °C

Features

- Low noise figure
- Large bandwidth
- Low phase noise oscillator
- High frequency stability of the oscillator
- High linearity
- Antenna port protected against static discharge
- Small and light-weight to allow easy pole mounting
- Tri-colour LED indicates unit status and gain mode setting
- Overvoltage protection and reverse polarity protection
- Remote power supply via output connector

Applications

- Multichannel Multipoint Distribution Services (MMDS)
- Digital broadcast systems (DVB-T, DVB-S)
- Analog and digital transmission systems

CE Konformität / CE Conformity

EMC directive 2014/30/EU
 Low voltage directive 2014/35/EU
 RoHS directive 2011/65/EU





Dimensions / Mounting holes (mm)

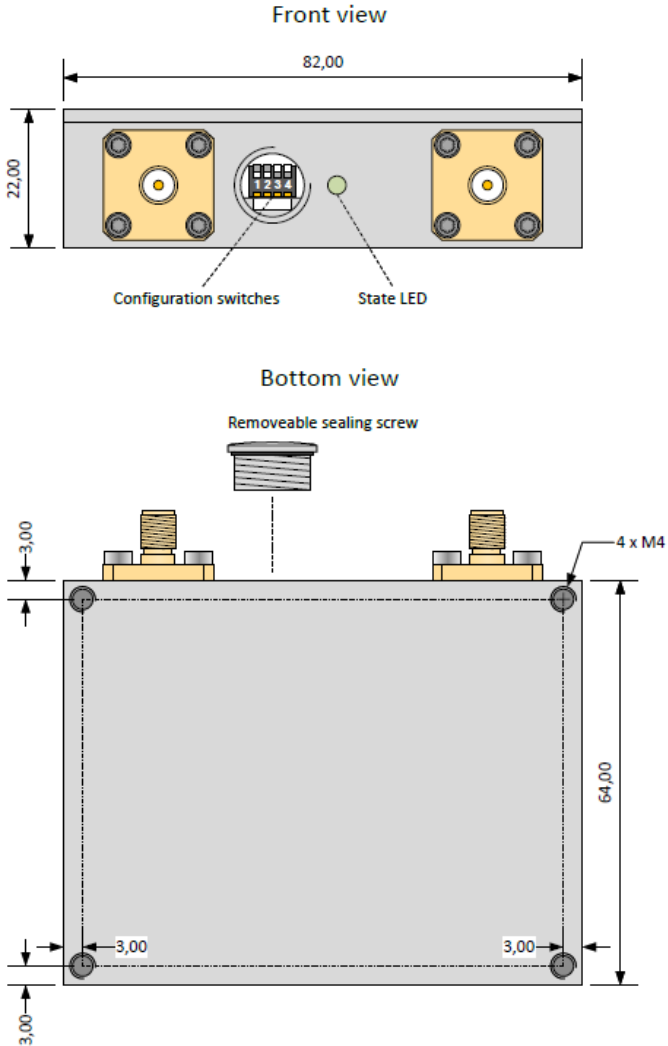



Configuration Switches / LED state

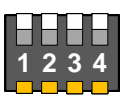

OFF
ON

Switch 1 + 2 - (Local oscillator frequency)

Switch 3 - (Gain)

Switch 4 - (User local oscillator frequency)

Device Error

LED state
Red

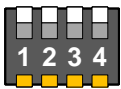

OFF
ON

Switch 1 - OFF
Switch 2 - OFF
LO 1400 MHz
IF 300 ... 500 MHz

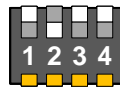

OFF
ON

Switch 1 - OFF
Switch 2 - ON
LO 2100 MHz
IF 400 ... 200 MHz

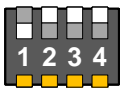

OFF
ON

Switch 1 - ON
Switch 2 - OFF
LO 1500 MHz
IF 200 ... 400 MHz

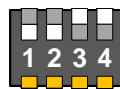

OFF
ON

Switch 1 - ON
Switch 2 - ON
LO 2200 MHz
IF 500 ... 300 MHz



OFF
ON

Switch 3 - OFF
Low Gain

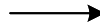

LED state
Green

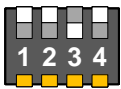

OFF
ON

Switch 3 - ON
High Gain



LED state
Blue

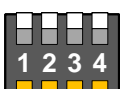

OFF
ON

Switch 4 - OFF
Local oscillator configuration with Switch 1 + 2

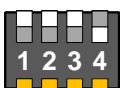

OFF
ON

Switch 4 - ON
Local oscillator configuration with Switch 1 + 2 disabled
User defined local oscillator frequency is enabled

In the case that **Switch 4** is in position **ON** the user defined local oscillator frequency is activated. This user defined local oscillator frequency can be selected in the range from 1300 ... 1700 MHz and from 1900 ... 2400 MHz. The frequency step size of the oscillator frequency is 10 MHz. The user defined oscillator frequency can be programmed with a special programming cable (see next page).

For example the oscillator frequency can be chosen to 1560 MHz or 2180 MHz .

Optional Connector PCB

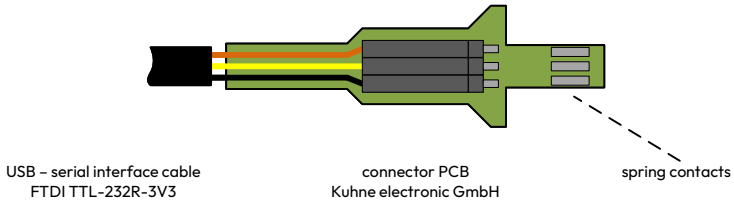

Configure the user defined local oscillator frequency

- connect the USB - serial interface cable with your PC
- start a terminal program on your PC (for example „hterm“)
- choose the COM port of the USB - serial interface cable

```
BAUDRATE 9600
DATABITS 8
STOPBITS 1
NO FLOW CONTROL
```

- insert the connector PCB with connected USB - serial interface cable into the configuration slot the spring contact must show to the top cover of the down converter
- power up the down converter
- send „s“ with the terminal program to the converter to get the state of the converter

```
Kuhne electronic GmbH - KU LNC 1719 C PRO

PLL locked
GAIN high
Selected LO frequency: 1400 MHz
User defined LO frequency: 1400 MHz
User defined LO frequency enabled
```

- send „1560LO“ with the terminal program to the converter to get set the user defined oscillator frequency to 1560 MHz
- power down the down converter
- remove the connector PCB

Mounting instructions

All LNCs from Kuhne electronic GmbH are labelled with at least protection class IP41 in accordance with DIN EN 60529, **unless a higher protection class is explicitly indicated in the valid specifications for the protection class on page 2.**

This provides information on the resistance of the unit against unwanted penetration of foreign bodies or moisture into the interior of the unit according to the following provision:

- Protected against granular solid foreign bodies (diameter ≥ 1 mm).
- Protection against falling spray up to 60° from vertical

The LNC modules have been designed with maximum protection against moisture. Nevertheless, water may enter the unit due to the design of the RF connectors, which is why some special features should be taken into account during installation.

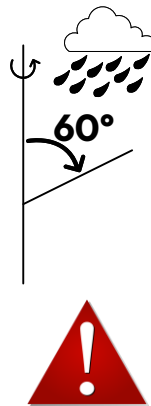
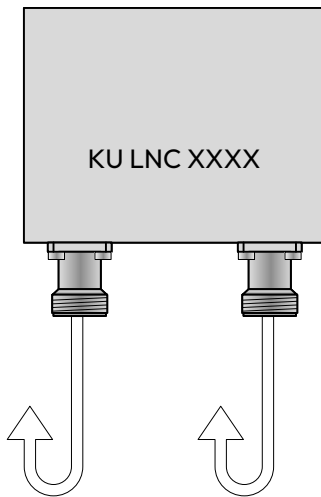

Mounting with the RF connectors vertically downwards

If possible, do not use cable connections with angled elbow connectors, but lead plugs out with a straight cable and a loop pointing downwards.

In the event of improper installation or handling that does not comply with our recommendations, Kuhne electronic reserves the right to exclude the warranty claim.



Application diagram

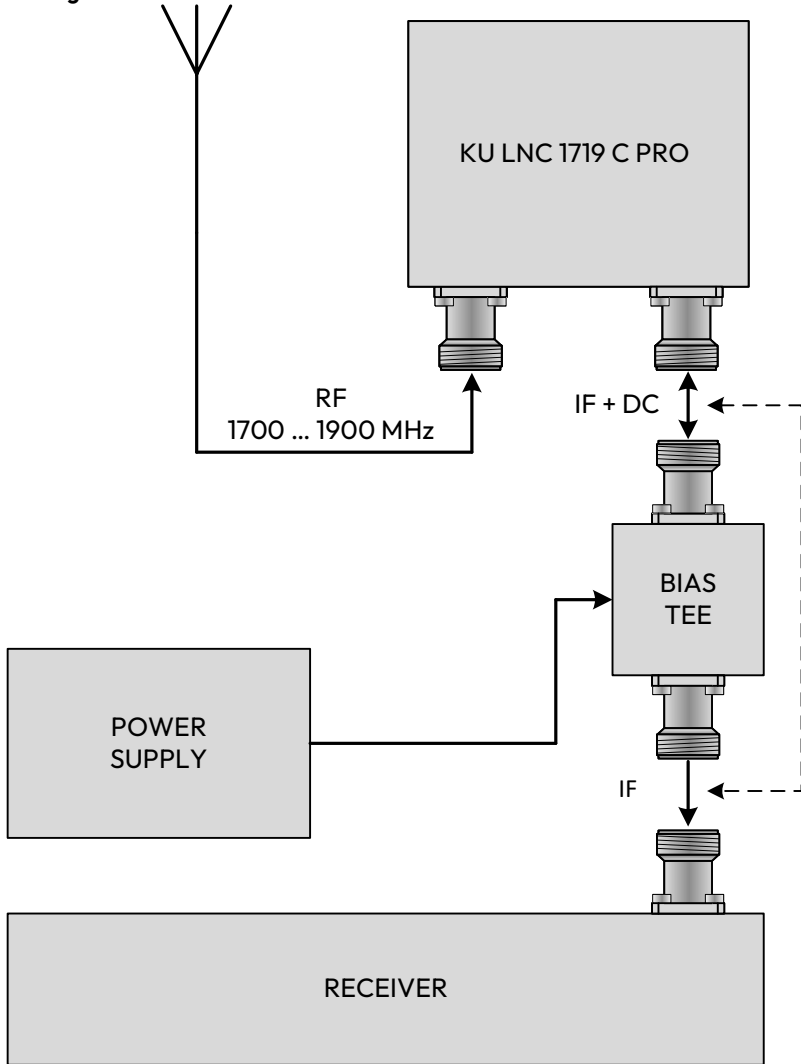

Typical performance

Typical phase noise at 1400 MHz
 local oscillator frequency

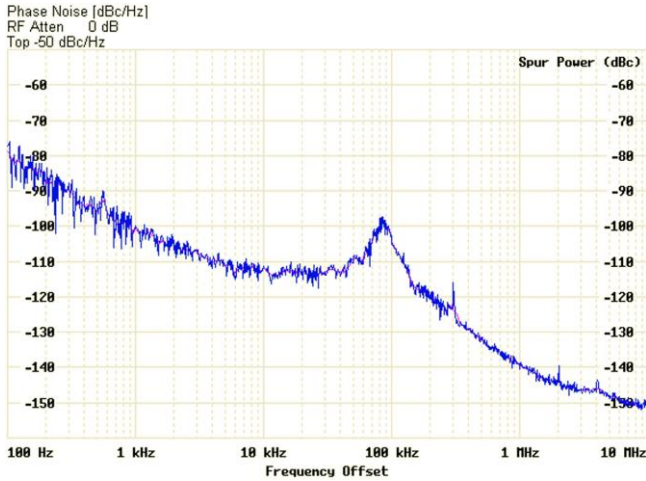

Typical gain and noise figure
 (1400 MHz local oscillator frequency)

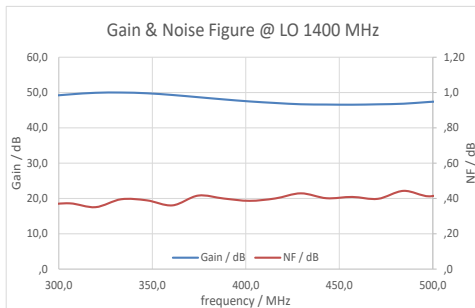

Typical gain and noise figure
 (2100 MHz local oscillator frequency)

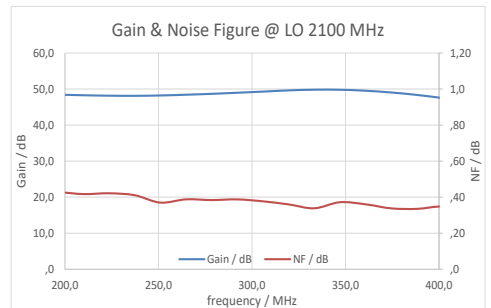

Directors: Ian Duke/Gustav Wenhold
 Reg no: HRB 3350 Hof, VAT-ID-No: DE 813343044, WEEEReg.-Nr. DE34186665

Kuhne electronic GmbH
 Scheibenacker 3, 95180 Berg
 Germany

A DIVISION OF

ALARIS
 THE RF TECHNOLOGY GROUP

