



ALARIS
KUHNE

INSPIRING THE NEXT RF SOLUTION

+49 (0) 9293 - 800 640
sales@kuhne.alaris.tech
www.kuhne.alaris.tech
Scheibenacker 3, 95180 Berg,
Germany

Version 1.0

KU LNC 127132 C PRO



Manual

Directors: Ian Duke/Gustav Wenhold
Reg no: HRB 3350 Hof, VAT-ID-No: DE 813343044, WEEEReg.-Nr. DE34186665

Kuhne electronic GmbH
Scheibenacker 3, 95180 Berg
Germany

A DIVISION OF

ALARIS
THE RF TECHNOLOGY GROUP



Specifications (Ta = 25 °C):

Type

Frequency range (RF)
 Noise figure @ 18 °C / LO 12450 MHz / IF amplifier ON)
 Gain (switchable) @ LO 12450 MHz
 Output IP3

Output frequency (RF in)

@ LO 12450 MHz
 @ LO 12300 MHz
 @ LO 12500 MHz
 @ LO 12600 MHz
 LO accuracy @ 18 °C
 LO frequency stability (0 ... 40 °C)

Phase noise @ 12450 MHz

@ 1 kHz
 @ 10 kHz
 @ 100 kHz

Operating parameters

Supply voltage
 Current consumption
 Power consumption

Mechanics

Input connector / impedance
 Output connector / impedance
 Case
 Dimensions (mm)
 Weight

Absolute ratings

Maximum RF input power
 Operating case temperature range

Features

- Low noise figure
- Large bandwidth
- Low phase noise oscillator
- High frequency stability of the oscillator
- High linearity
- Antenna port protected against static discharge
- Small and light-weight to allow easy pole mounting
- Tri-colour LED indicates unit status and gain mode setting
- Overvoltage protection and reverse polarity protection
- Remote power supply via output connector

KU LNC 127132 C PRO

12750 ... 13250 MHz
 typ. 1.9 dB, max. 2.4 dB
 typ. 42 dB (high gain mode) / typ. 20 dB (low gain mode)
 typ. +22 dBm (high gain mode) / typ. +8 dBm (low gain mode)

IF = 300 ... 800 MHz
 IF = 450 ... 950 MHz
 IF = 250 ... 750 MHz
 IF = 150 ... 650 MHz
 +/- 2 ppm
 +/- 3 ppm

typ. -83 dBc/Hz
 typ. -89 dBc/Hz
 typ. -94 dBc/Hz

+9 ... 36 V DC
 typ. 250 mA @ 12V (IF amplifier enabled)
 typ. 3.0 W

SMA-female, 50 ohms
 SMA-female, 50 ohms
 milled aluminium, IP43
 82 x 64 x 22
 typ. 230 g

1 mW (0 dBm)
 -20 ... +55 °C

Applications

- Multichannel Multipoint Distribution Services (MMDS)
- Digital broadcast systems (DVB-T, DVB-S)
- Analog and digital transmission systems

Products are only to be sold to competent companies or to radio amateurs with a licence.
 For operating high frequency modules legal instructions must be followed.

CE Konformität / CE Conformity

EMC directive 2014/30/EU
 Low voltage directive 2014/35/EU
 RoHS directive 2011/65/EU





Dimensions / Mounting holes

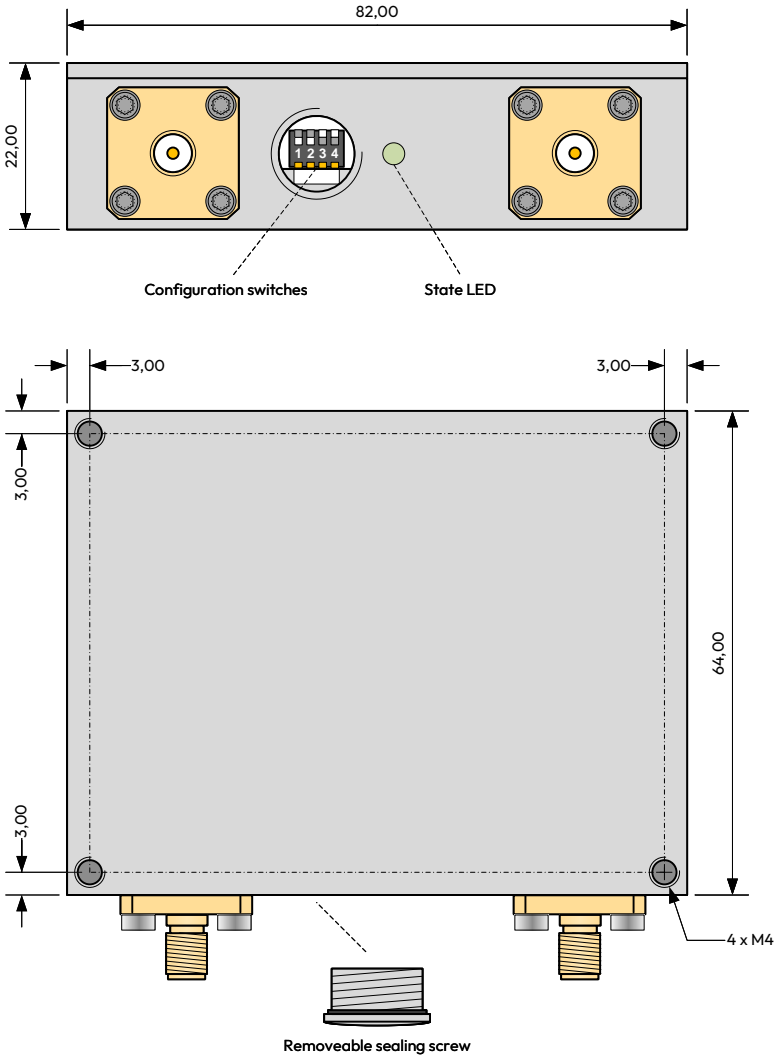



Configuration Switches / LED state

	↑ OFF	Switch 1 + 2 - (Local oscillator frequency)	Device Error
	↓ ON	Switch 3 - (Gain)	
		Switch 4 - (User local oscillator frequency)	

	↑ OFF	Switch 1 - OFF Switch 2 - OFF LO 12450 MHz IF 300 ... 800 MHz		↑ OFF	Switch 1 - OFF Switch 2 - ON LO 12300 MHz IF 450 ... 950 MHz
	↓ ON			↓ ON	

	↑ OFF	Switch 1 - ON Switch 2 - OFF LO 12500 MHz IF 250 ... 750 MHz		↑ OFF	Switch 1 - ON Switch 2 - ON LO 12600 MHz IF 150 ... 650 MHz
	↓ ON			↓ ON	

	↑ OFF	Switch 3 - OFF Low Gain	→	LED state Green	
	↓ ON				

	↑ OFF	Switch 3 - ON High Gain	→	LED state Blue	
	↓ ON				

	↑ OFF	Switch 4 - OFF
	↓ ON	Local oscillator configuration with Switch 1+2

	↑ OFF	Switch 4 - ON
	↓ ON	Local oscillator configuration with Switch 1 + 2 disabled User defined local oscillator frequency is enabled

In the case that **Switch 4** is in position **ON** the user defined local oscillator frequency is activated. This user defined local oscillator frequency can be selected in the range from 12300 ... 12600 MHz. The frequency step size of the oscillator frequency is 2 MHz. The user defined oscillator frequency can be programmed with a special programming cable.

For example the oscillator frequency can be chosen to 12350 MHz or 12560 MHz.

Optional Connector PCB

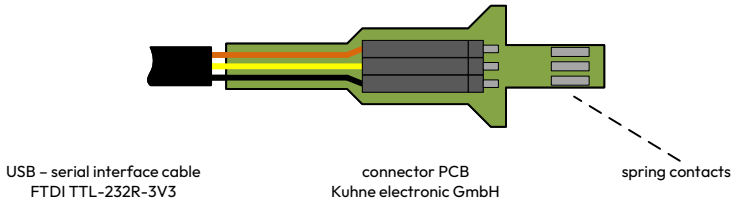

Configure the user defined local oscillator frequency

- connect the USB - serial interface cable with your PC
- start a terminal program on your PC (for example „hterm“)
- choose the COM port of the USB - serial interface cable

```
BAUDRATE 9600
DATABITS 8
STOPBITS 1
NO FLOW CONTROL
```

- insert the connector PCB with connected USB - serial interface cable into the configuration slot the spring contact must show to the top cover of the down converter
- power up the down converter
- send „s“ with the terminal program to the converter to get the state of the converter

```
Kuhne electronic GmbH - KU LNC 127132 C PRO

PLL locked
GAIN high
Selected LO frequency: 12350 MHz
User defined LO frequency: 12350 MHz
User defined LO frequency enabled
```

- send „12350LO“ with the terminal program to the converter to get set the user defined oscillator frequency to 8400 MHz
- power down the down converter
- remove the connector PCB

Mounting instructions

All LNCs from Kuhne electronic GmbH are labelled with at least protection class IP41 in accordance with DIN EN 60529, **unless a higher protection class is explicitly indicated in the valid specifications for the protection class on page 2.**

This provides information on the resistance of the unit against unwanted penetration of foreign bodies or moisture into the interior of the unit according to the following provision:

- Protected against granular solid foreign bodies (diameter ≥ 1 mm).
- Protection against falling spray up to 60° from vertical

The LNC modules have been designed with maximum protection against moisture. Nevertheless, water may enter the unit due to the design of the RF connectors, which is why some special features should be taken into account during installation.

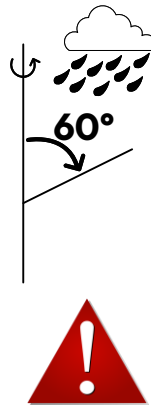
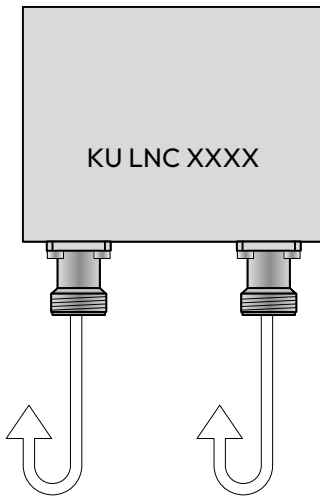

Mounting with the RF connectors vertically downwards

If possible, do not use cable connections with angled elbow connectors, but lead plugs out with a straight cable and a loop pointing downwards.

In the event of improper installation or handling that does not comply with our recommendations, Kuhne electronic reserves the right to exclude the warranty claim.

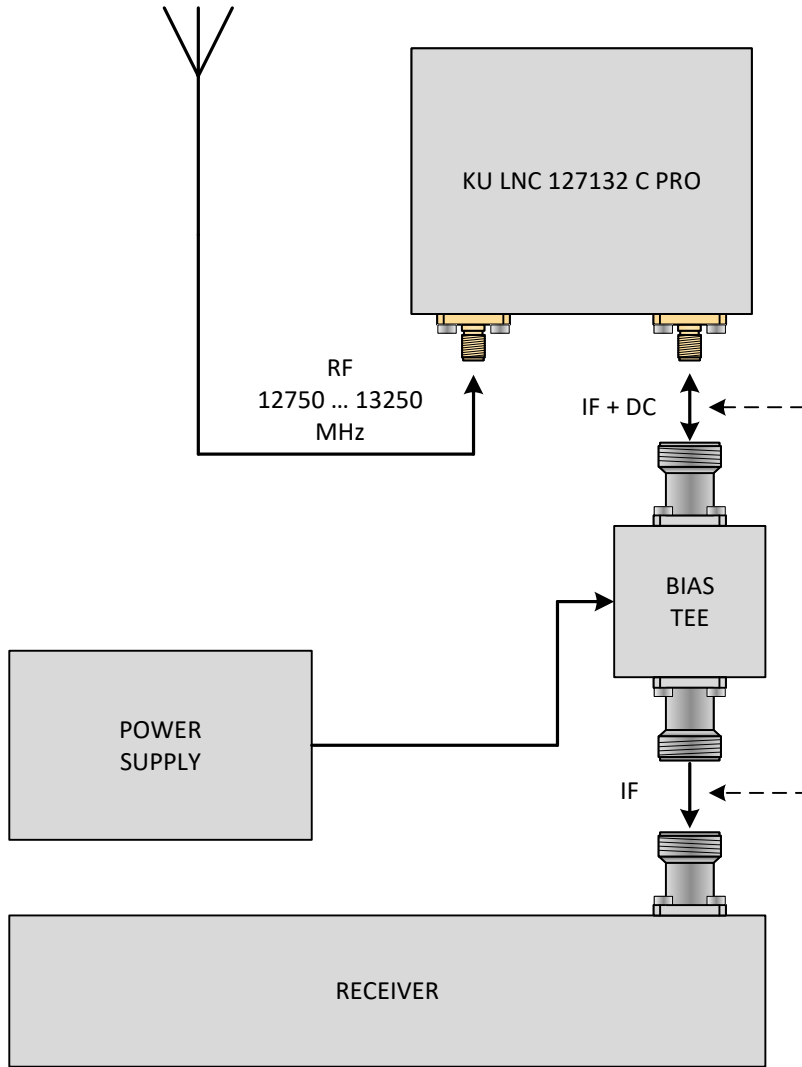



ALARIS
KUHNE

INSPIRING THE NEXT RF SOLUTION

+49 (0) 9293 - 800 640
sales@kuhne.alaris.tech
www.kuhne.alaris.tech
Scheibenacker 3, 95180 Berg,
Germany

Gain (12450 MHz local oscillator frequency)

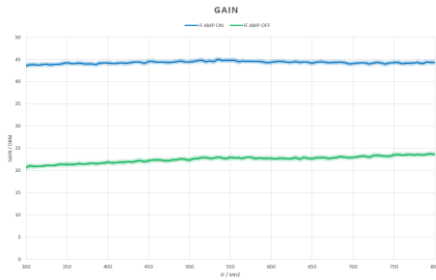

Noise figure (12450 MHz local oscillator frequency)

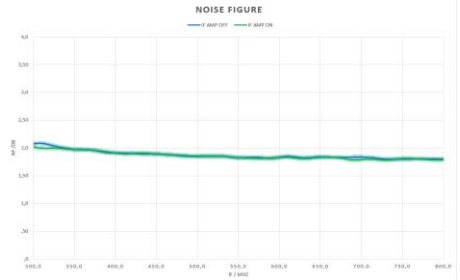

Output P1dB (12450 MHz local oscillator frequency)

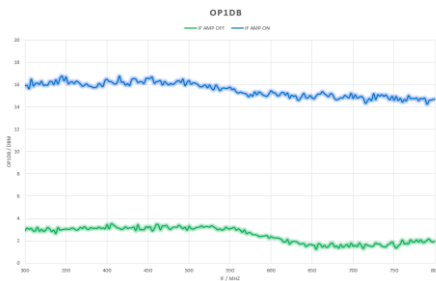

Output IP3 (12450 MHz local oscillator frequency)

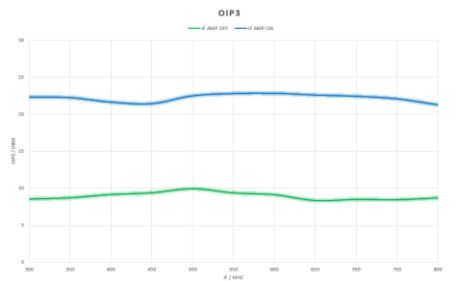

Gain vs. Temp. IF AMP OFF (12450 MHz local oscillator frequency)

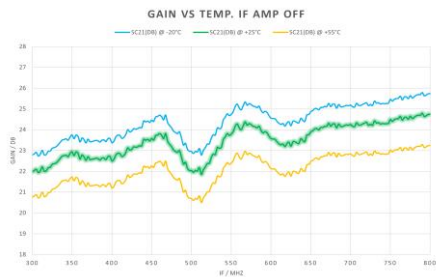

Gain vs. Temp. IF AMP ON (12450 MHz local oscillator frequency)

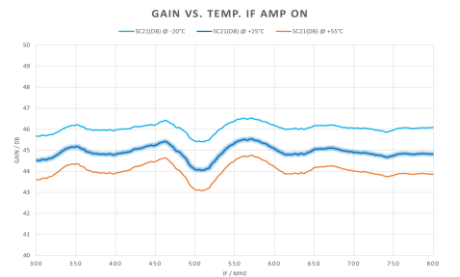

Directors: Ian Duke/Gustav Wenhold
Reg no: HRB 3350 Hof, VAT-ID-No: DE 813343044, WEEEReg.-Nr. DE34186665

Kuhne electronic GmbH
Scheibenacker 3, 95180 Berg
Germany

A DIVISION OF

ALARIS
THE RF TECHNOLOGY GROUP

