

Compact Direction Finding Antenna System

400 – 6000 MHz

Product Code: DFS-A0250

VERSION: 1.3



PRODUCT DESCRIPTION:

The DFS-A0250 direction finding antenna system covers a frequency range of 400 MHz to 6000 GHz.

The full-size elements on all bands give excellent DF sensitivity. Ultimate angular resolution for strong signals is well under 1° for most of the frequency range. Dipole elements provide good cross-polarization rejection, and fair performance for signals arriving from up to 15° above or below the horizon.

This DF antenna is designed to be used either a 5- or 2-channel phase-sensitive receiver, and correlative algorithm. Characterization of the antenna can be performed on request.

ELECTRICAL FEATURES:

- Full-size, wideband DF
- 5-element interferometer
- Full Band Monitoring

MECHANICAL FEATURES:

- Designed for tower mounting
- Compact Size

SPECIFICATIONS:

Electrical:	
Frequency range	400 – 6000 MHz
Polarisation	Vertical
DF:	
Frequency range	400 – 6000 MHz
Band B	400 – 1000 MHz
Band C	1000 – 3000 MHz
Band D	3000 – 6000 MHz
Nominal input impedance	50 Ω
Antenna type	5-element DF interferometer
Channels per band	5
Monitoring:	
Frequency Range	400 – 6000 MHz
Switch:	
Frequency range	400 – 6000 MHz
Frequency bands	Band B: 400 – 1400 MHz; Band C: 500 – 3600 MHz; Band D: 2000 – 6000 MHz
Channels per band	5
Input VSWR	< 2.5:1
Gain	8 ± 2 dB
Noise figure	< 10 dB
OIP3 (typical)	400 MHz 30 dBm 3 GHz 25 dBm 6 GHz 22 dBm
Maximum input level	30 dBm CW, 45 dBm pulse
Power and control interface:	
Power supply	19 – 36 V DC, 1A at 24 V
Control interface	EIA-485 (RS-485)
Switching time	< 50 μS
Time to receive control byte (RS-485, 115.2 kbps)	< 100 μS
Total switching time	< 150 μS
RF Interface:	
Connectors	6 x N female
Mechanical:	
Maximum wind speed	Operational - 160 km/h (without ice load) Max 251 km/h gusts in a debris free environment, short interval gusts only
Assembled height	2.1 m
Assembled diameter (max)	0.77 m
Weight of antenna	45 kg
Environmental: designed to meet the following specifications	
Operating Temperature	-30°C to +70°C
IP Rating	IP55

Compact Direction Finding Antenna System

400 – 6000 MHz

Product Code: DFS-A0250

VERSION: 1.3

DF ANTENNA DIMENSIONS:

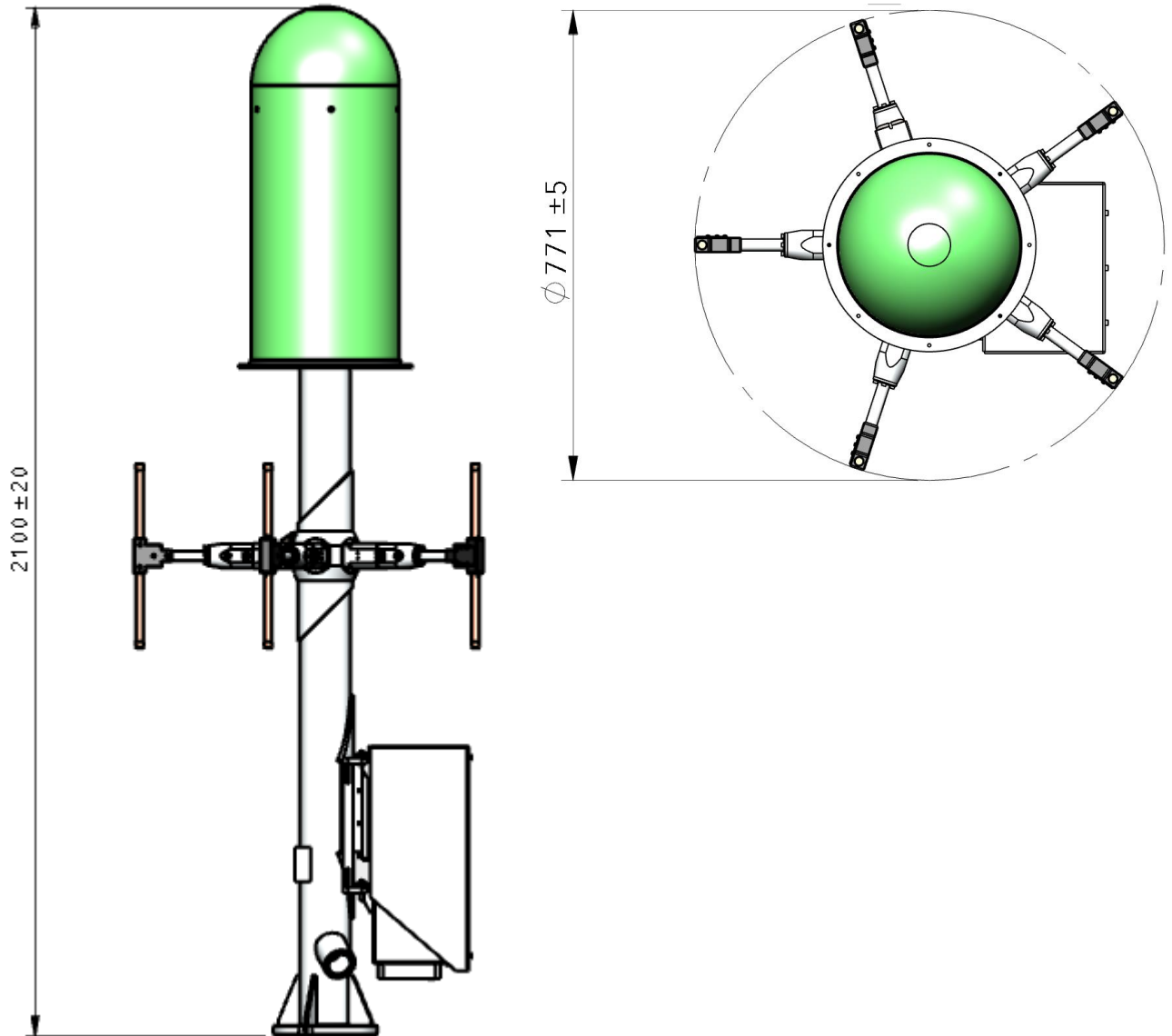

ENVIRONMENTAL SPECIFICATIONS AND TESTS (designed to meet the following):

Vibration	Designed for MIL-STD-810E method 516.4, category 8
Mechanical shock	Designed for MIL-STD-810E method 516.4 (40 g)
Low temperature storage	Designed for MIL-STD-810E method 502.3 (-30 °C)
High temperature storage	Designed for MIL-STD-810E method 501.3 (+70 °C)
Rain	Designed for MIL-STD-810E 506.3 procedure I (95% RH)
Artificial weathering (UV stability) total duration 500 h	Designed for BS 3900: part F16, method A. lamps: UV-B (313) Product exceeds requirements set out by the British Standard
Temperature and humidity	Designed for MIL-STD-810E method 507.3
Salt / fog	Designed for MIL-STD-810E 509.3 procedure I
Dust	Designed for MIL-STD-810E 510.3 procedure II

Compact Direction Finding Antenna System

400 – 6000 MHz

Product Code: DFS-A0250

VERSION: 1.3

DF SENSITIVITY GRAPH:

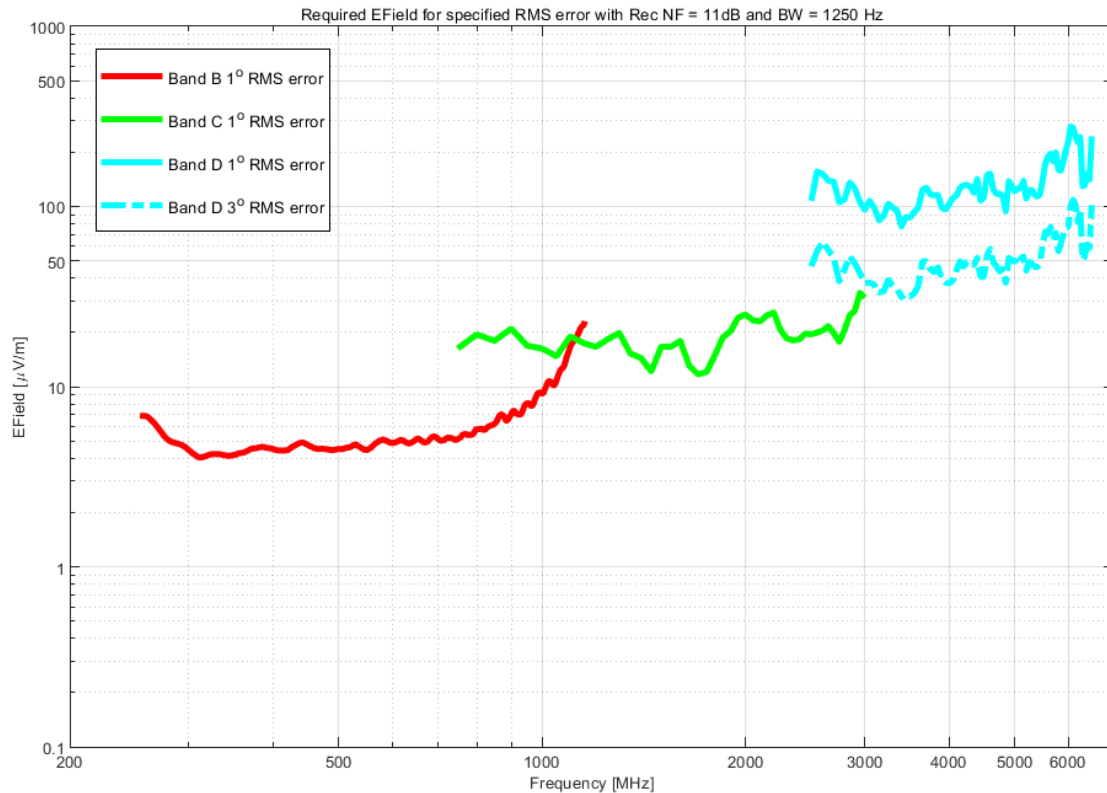

The graph illustrates the direction finding sensitivity of a typical system. The sensitivity is measured using an IF bandwidth of 1.25 kHz and **without** averaging. The graph shows the minimum signal required to obtain a bearing fluctuation of less than 1° for the frequency range 400 to 3000 MHz, less than 3° for the frequency range 3000 to 6000 MHz. **The values should be adapted for the system in question if it uses a different bandwidth and receiver noise figure, or if considering a different required accuracy.**

INTEROPERABILITY WITH DF RECEIVERS:

The DF sensitivity of the full system is highly dependent on the receivers, processing and algorithm used, as well as the characterization table density. The graph above assumes a 5-channel, low noise receiver and correlative algorithm. The sensitivity will be between 1 and 10 dB worse with a 2-channel receiver system.

The 1 to 6 GHz band of this antenna is designed for efficient operation with a commutated 2-channel receiver. Special attention has been paid to the nulls which usually occur in this band due to the large diameter mast. Receiver systems with two channels, commutated to measure five antennas, are sensitive to nulls in the element patterns. Depending on the receiver and algorithm, reducing the null depth leads to a more reliable system.