SPECIFICATIONS:

Product codes:		
MONO-A0025	1000 W power handling	
MONO-A0025-02	1200 W power handling	
Electrical:		
Frequency	1 – 30 MHz	
VSWR	< 3:1	
Nominal input impedance	50 Ω	
Feed power handling	MONO-A0025	MONO-A0025-02
	1000 W	1200 W
Efficiency	Typical is above 50% down to 15 MHz, reducing to 10% at 8 MHz, and 1 % at 5 MHz	
Directivity	0 dBi (± 0.5 dB) dependent on the groundplane	
Connector	N-type (female)	
Mechanical:		
Dimensions (l x d of base)	6000 mm x 330 mm	
Weight	< 30 kg	
MTBF	30000 hours	
Environmental: designed to meet the following specifications		
Wind survival	120 km/h	
Temperature (operational)	-40 °C to +70 °C	
Shock	40 g's for 10 ms (all axis)	
Vibration	MIL-STD-810E (514.5) 2.3.9.b track laying vehicles	
Water ingress rating	MIL-STD-820F (506.4)	
Max speed of vehicle (antenna operational)	30 km/h	
Max speed of vehicle (antenna non-operational)	80 km/h	

PRODUCT FEATURES:

- Small and light – significantly shorter in length than a full-size dipole for this frequency range
- VSWR better than 3:1 across the entire frequency range.
- No matching unit required, so ideal for wideband and frequency-agile applications

APPLICATIONS:

- Wideband high-power transmission
- Frequency agile communications
- Spectrum monitoring

PRODUCT DESCRIPTION:

The MONO-A0025 is a wideband dual monopole antenna that covers the frequency range of 1 MHz to 30 MHz at an input power of 1000 W.

The antenna pattern is essentially omni-directional, making it ideal for wideband high-power applications such as improvised explosive device (IED) suppression.

This antenna has a nice compact footprint when mounted and being relatively light in weight makes it suitable for any rapid deployment applications like vehicles and shelter roof tops where larger antennas would be impractical. The whips can be tied back in a variety of ways to ensure best performance and mobility trade-offs.

The whip sections of the antenna are easily removed from the base and then stored in a canvas bag for easy transportation and storage.

For most applications the base can then remain attached as a fixed low profile installation that also gets a canvas bag to cover it when not in use. This further reduces the assembly time to only a couple of minutes in the field. The assembly mechanism is designed to be highly shock and vibration resistant. The MONO-A0025 is constructed entirely from corrosion-resistant materials and specified over a wide operating temperature range: -40 °C to + 70 °C (no icing).

Wideband HF Monopole

1 – 30 MHz

Product Code: MONO-A0025

VERSION: 3.3

VSWR AND GAIN:

NOTE: Provided gain data is REALISED gain and **includes** effect of mismatch loss and efficiency

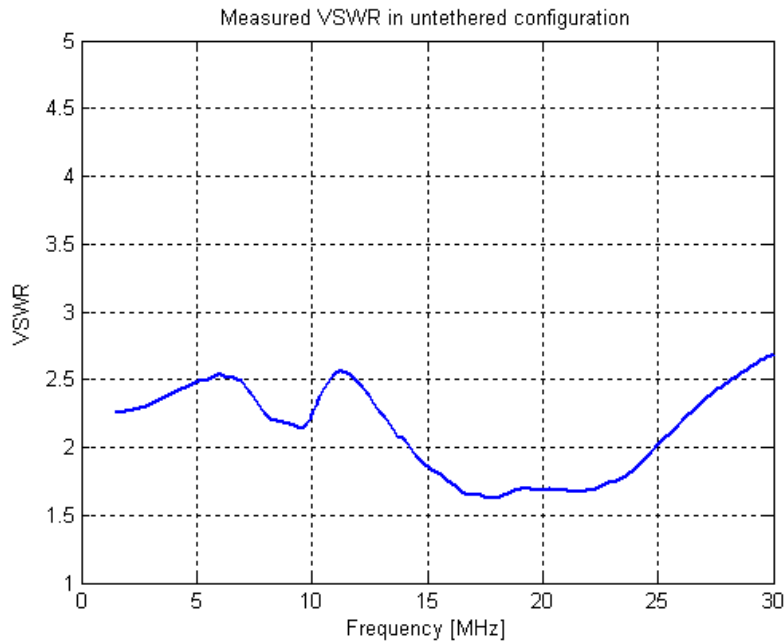

Figure 1: Measured antenna VSWR in untethered configuration

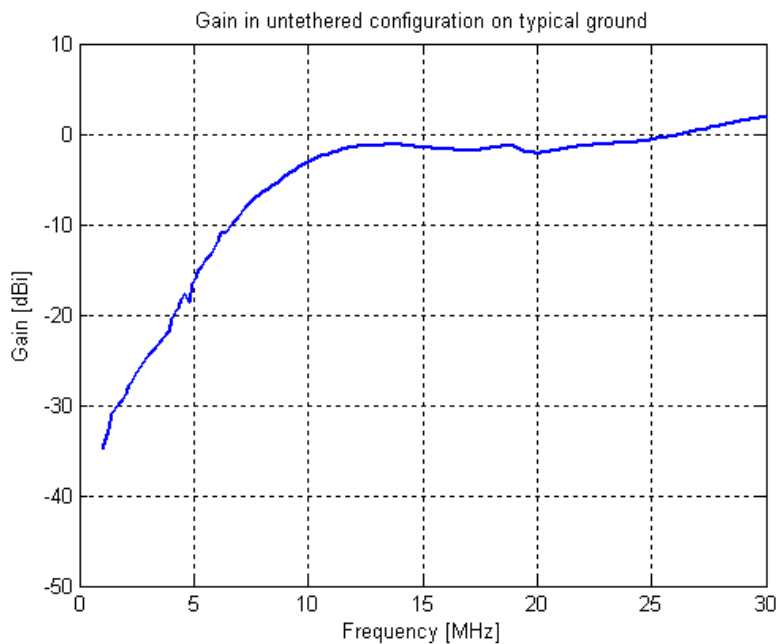

Figure 2: Antenna gain in untethered configuration

Wideband HF Monopole

1 – 30 MHz

Product Code: MONO-A0025

VERSION: 3.3

DEPLOYMENT OPTIONS:

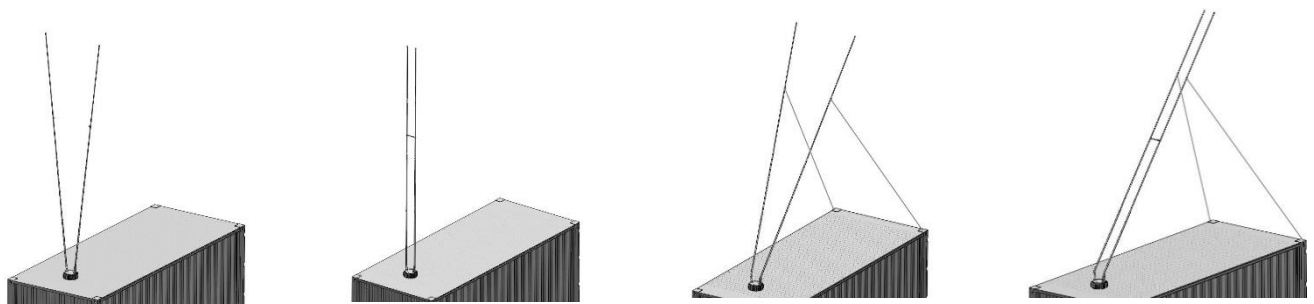

Untethered

Tied together

Splayed back

Tied back



MECHANICAL DRAWINGS:

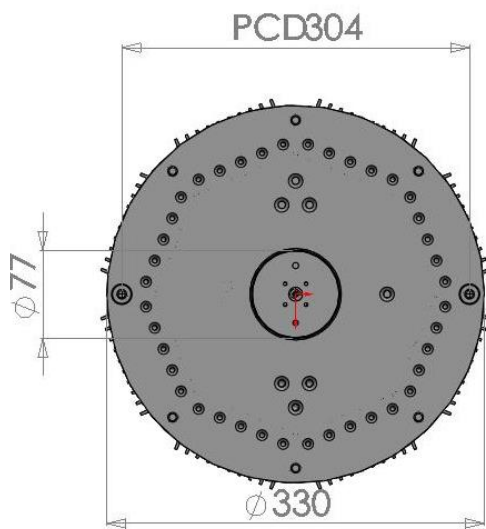

Outline of base with dimensions

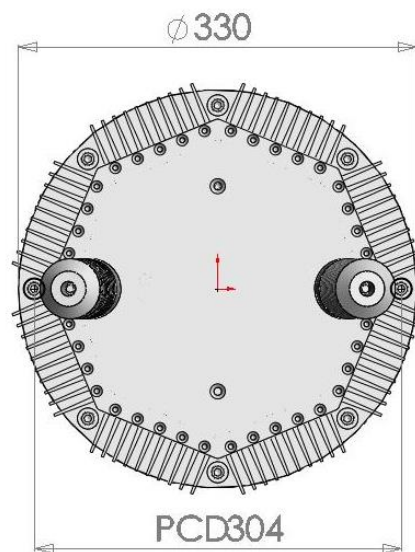

Top view of base with dimensions