

Wideband Dual-Polarised LPDA Antenna

30 – 2500 MHz

Product Code: LPDA-A0175

VERSION: 1.2

SPECIFICATIONS:

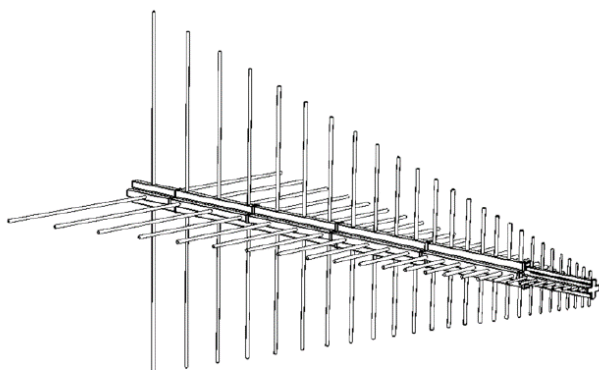

* Picture representative only

PRODUCT FEATURES:

- Wideband frequency 30 MHz to 2500 MHz
- Low VSWR
- High gain of typically 6 - 7 dBi
- Rugged construction and compact packaging
- Also configured for fixed applications

PRODUCT APPLICATIONS:

- Wideband monitoring

Electrical:	
Frequency range	30 – 2500 MHz
VSWR	< 2.5:1 over the frequency band
Nominal input impedance	50 Ω
Feed power handling	Receive only
Gain	6 - 7 dBi typical over the frequency band.
E-plane 3 dB beamwidth	60 ° typical
H-plane 3 dB beamwidth	120 ° typical
Polarisation	Dual linear
Port-Port Isolation	15dB
Connectors	2x N-type female
Mechanical:	
Dimensions (w x h x l)	4000mm x 4000 mm x 5000 mm
Material	Aluminium, stainless steel, fibreglass
Total mass	TBC - 70 kg (incl. isolation pole)
Mounting	Centre mount on supplied isolation pole
Environmental: designed to meet the following specifications	
Wind survival	160 km/h when guyed
Water and dust resistance	IP66
Temperature range	-30 °C to +70 °C
Corrosion	Appropriate anti-corrosion measures are taken in the design of antenna for harsh environmental conditions

**All specifications shown above are indicative and preliminary only

PRODUCT DESCRIPTION:

The LPDA-A0175 is a dual polarised directional log-periodic dipole array primarily designed for EW monitoring applications to cover the 30 MHz to 2500 MHz frequency band with a typical gain of 6 dBi.

This antenna is supplied with a boom that breaks into three sections and all the elements can be removed and stored in a roll-up canvas bag for compact storage.

This antenna can be customised if required, for different frequency ranges handling.

Wideband Dual-Polarised LPDA Antenna

30 – 2500 MHz

Product Code: LPDA-A0175

VERSION: 1.2

VSWR AND GAIN GRAPHS:

**All specifications shown below are indicative and preliminary only

LOW FREQUENCY BAND VSWR:

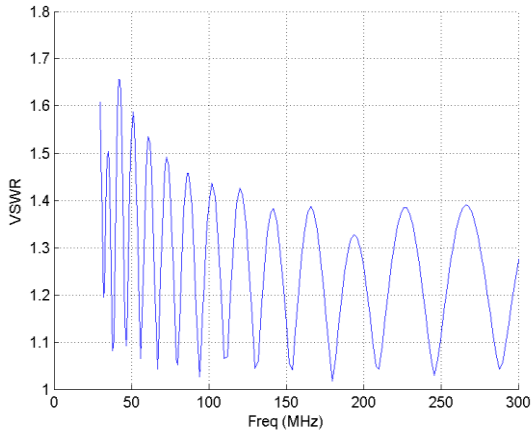

HIGH FREQUENCY BAND VSWR:

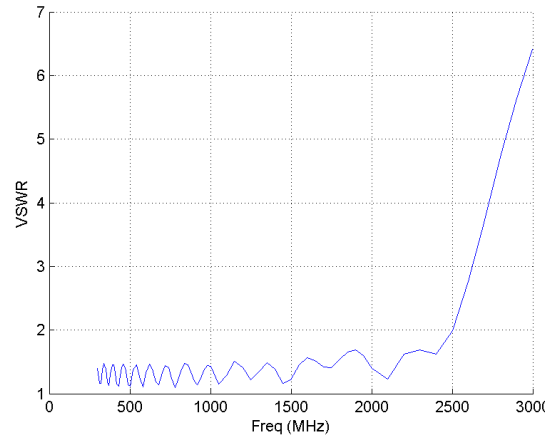

LOW FREQUENCY BAND GAIN:

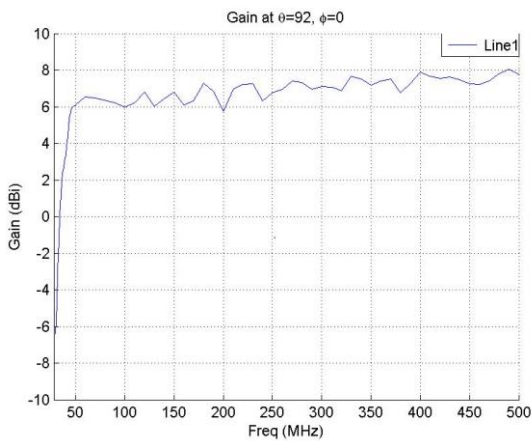

HIGH FREQUENCY BAND GAIN:

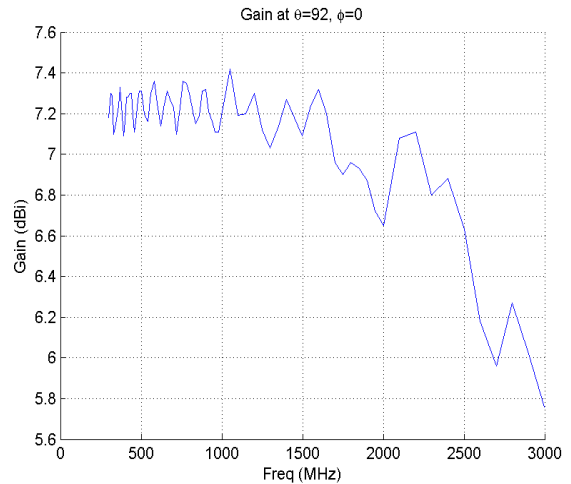

E-plane plot at 30 MHz:

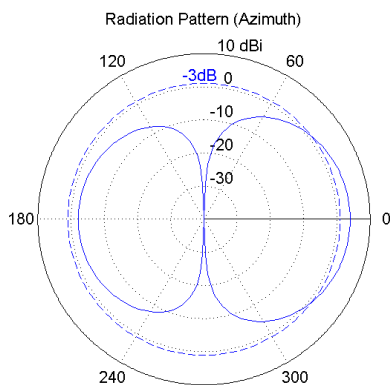

H-plane plot at 30 MHz:

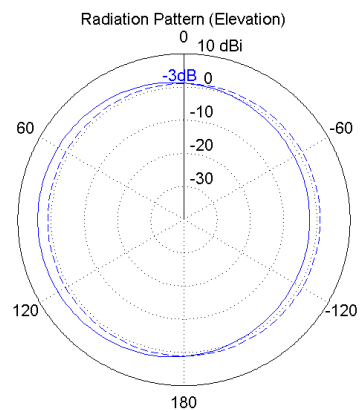

Wideband Dual-Polarised LPDA Antenna

30 – 2500 MHz

Product Code: LPDA-A0175

VERSION: 1.2

E-plane plot at 100 MHz:

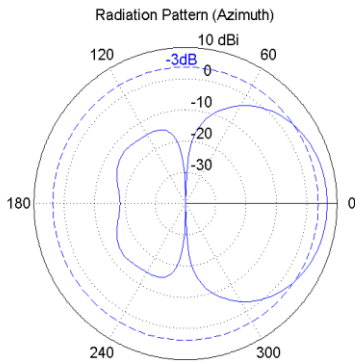

H-plane plot at 100 MHz:

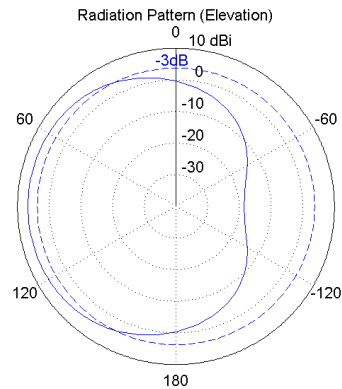

E-plane plot at 300 MHz:

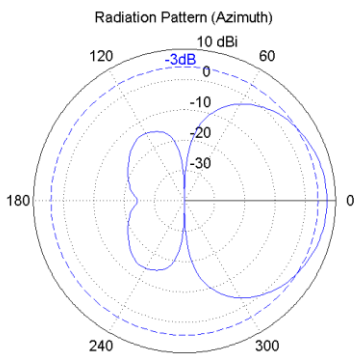

H-plane plot at 300 MHz:

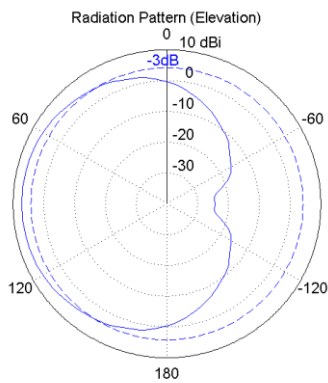

E-plane plot at 1000 MHz:

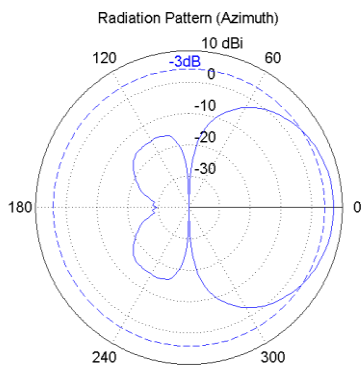

H-plane plot at 1000 MHz:

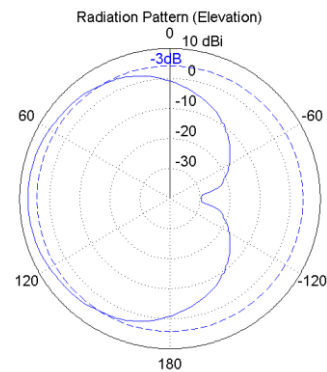

E-plane plot at 2500 MHz:

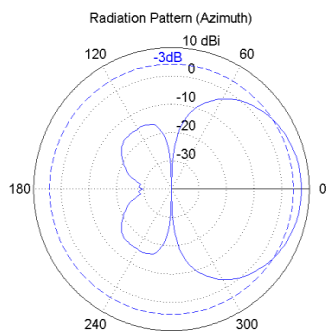

H-plane plot at 2500 MHz:

